

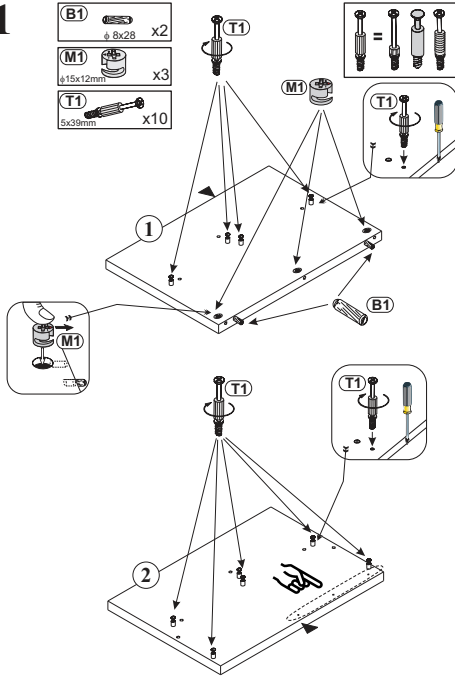

1

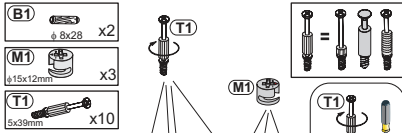

2

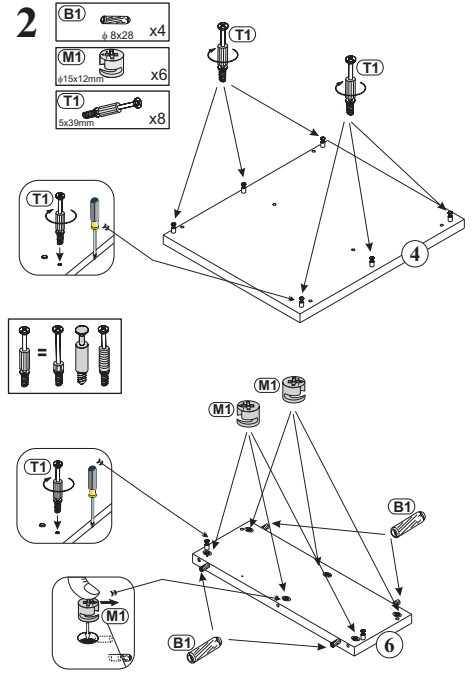
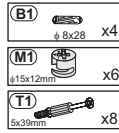

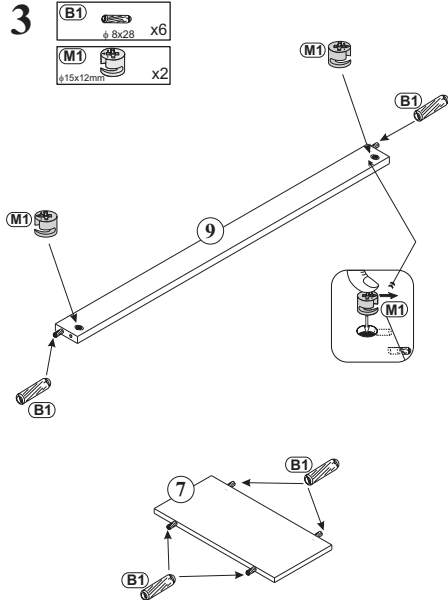
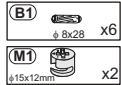

3

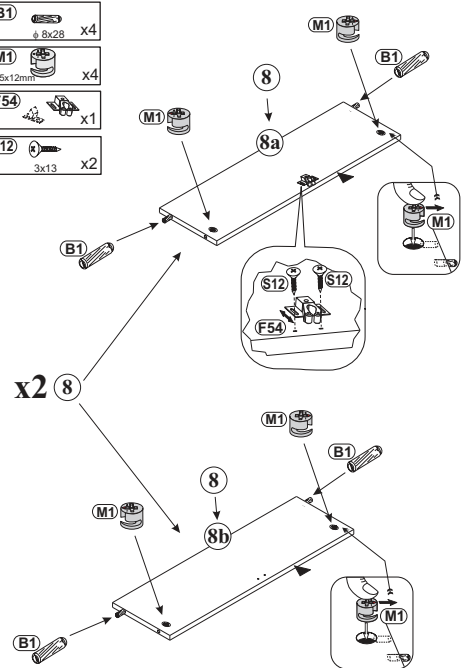
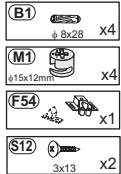

4





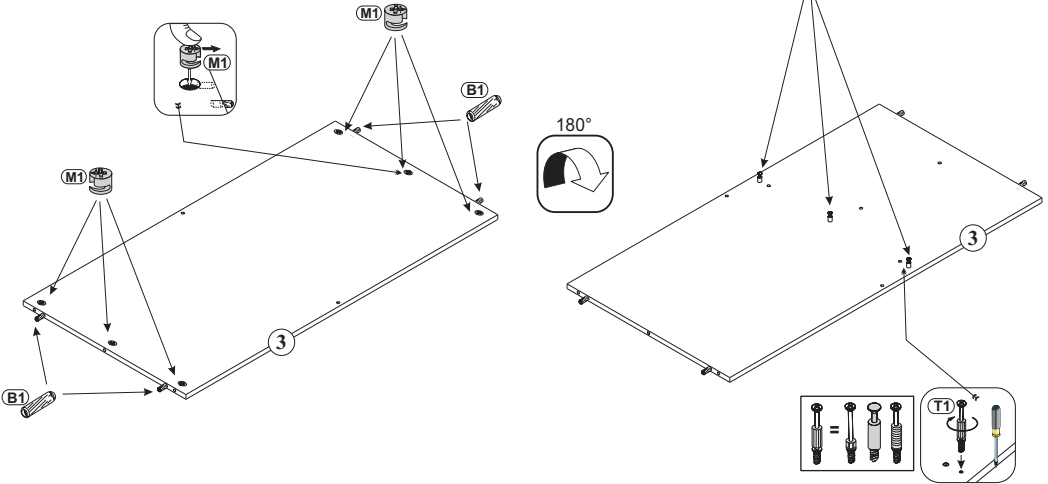

5

- B1**   $\phi$  8x28 x4
- M1**   $\phi$  15x12mm x6
- T1**  5x39mm x3



6

- R53**  x1L/1R
- F54**  x1
- S12**  3x13 x2
- S12**  4x20 x10

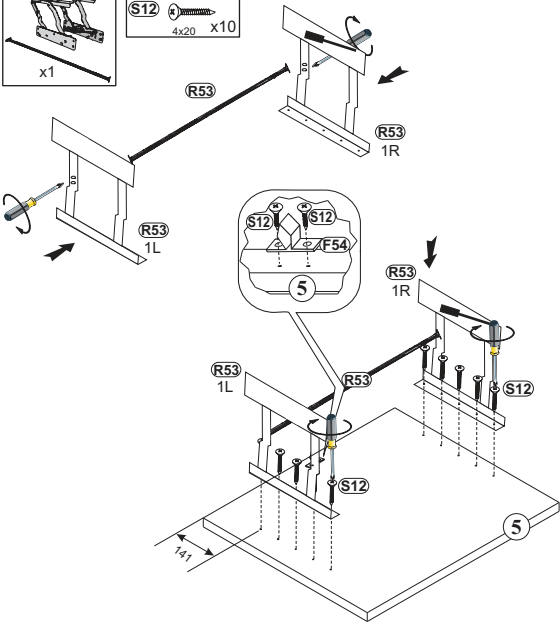

7

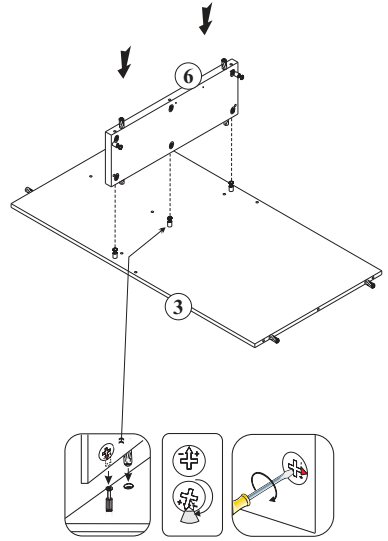

8

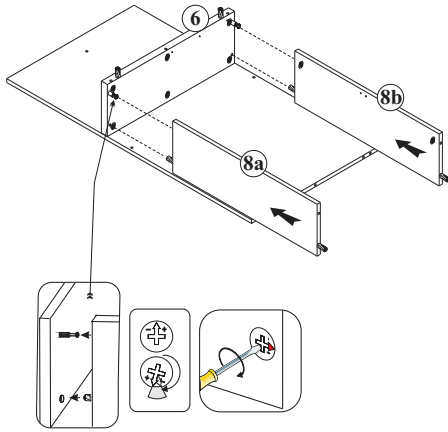

9

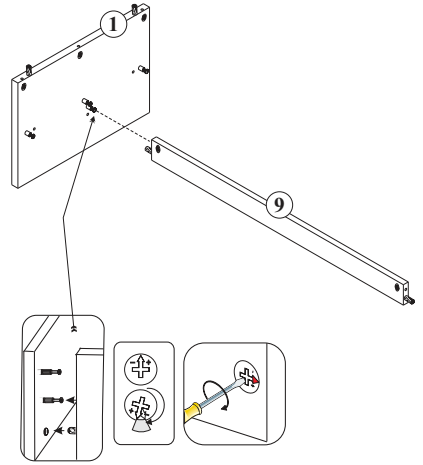

10

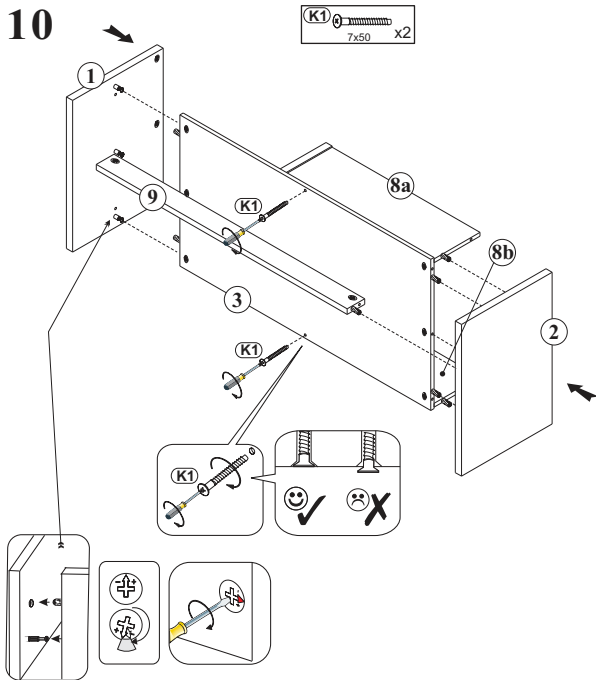

11

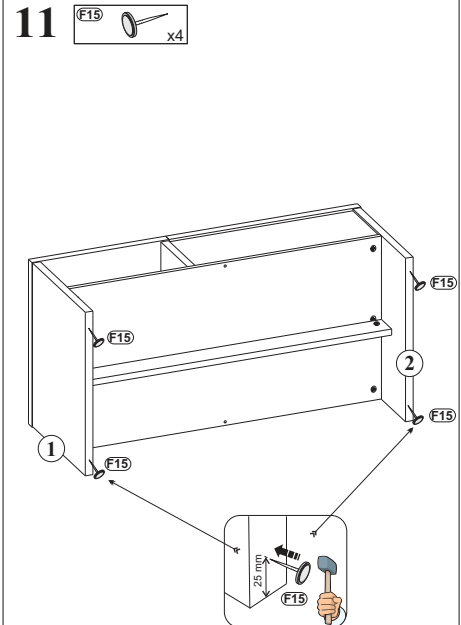

12

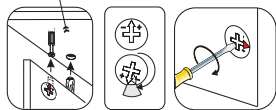
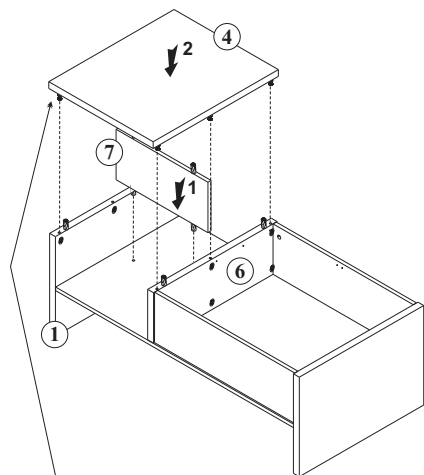

13

- S12 4x20 x12
- C14 a:20mm x4
- C142 b:20mm x8

